

T-Rex POST

FITNESS STATION™

- 01- Loop Post w' Elevate Rope Trainer, Y-Extender & Rings
- 02- Extended Pull-Up Bar
- 03- Standard Post w' ADJ. AB Board
- 04- Side Rail Pull-Up Bars
- 05- Globe Grips
- 06- Monkey Bar Bridge with Lower Rails
- 07- Standard Post w' ADJ. Dip
- 08- Ergo-Grip Pull-Up Bar
- 09- Standard Post w' Battle Rope
- 10- Pull-Up Bar
- 11- Standard Post w' ADJ. Step

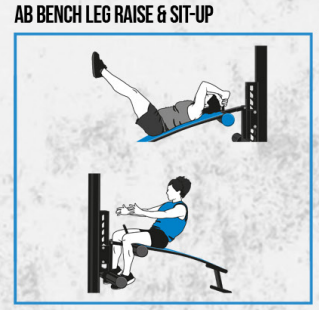
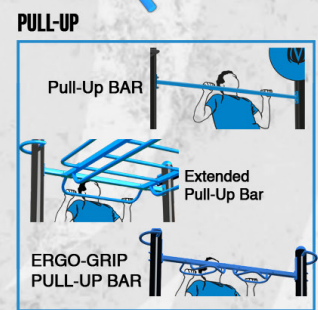
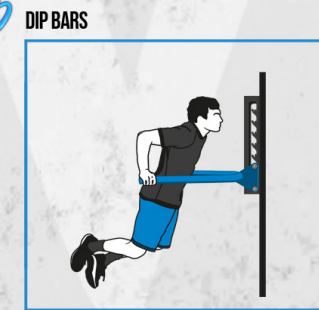
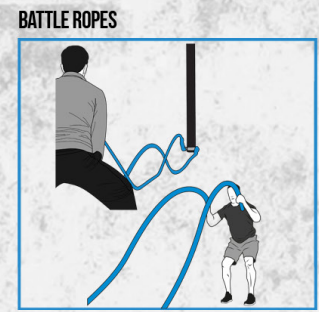
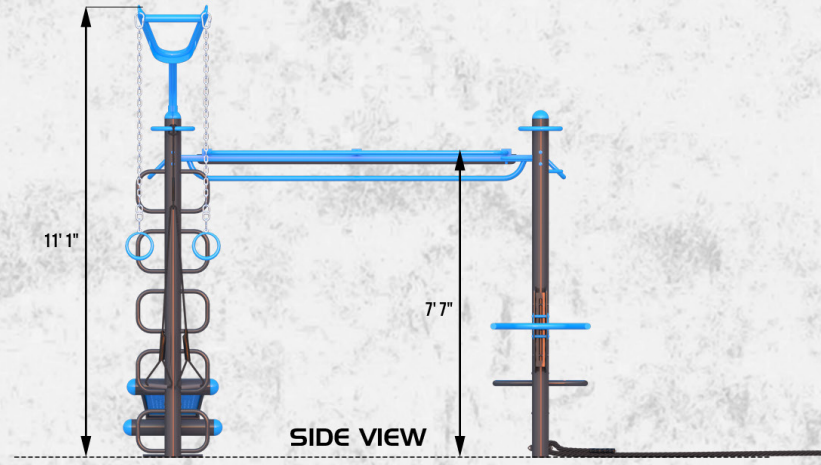
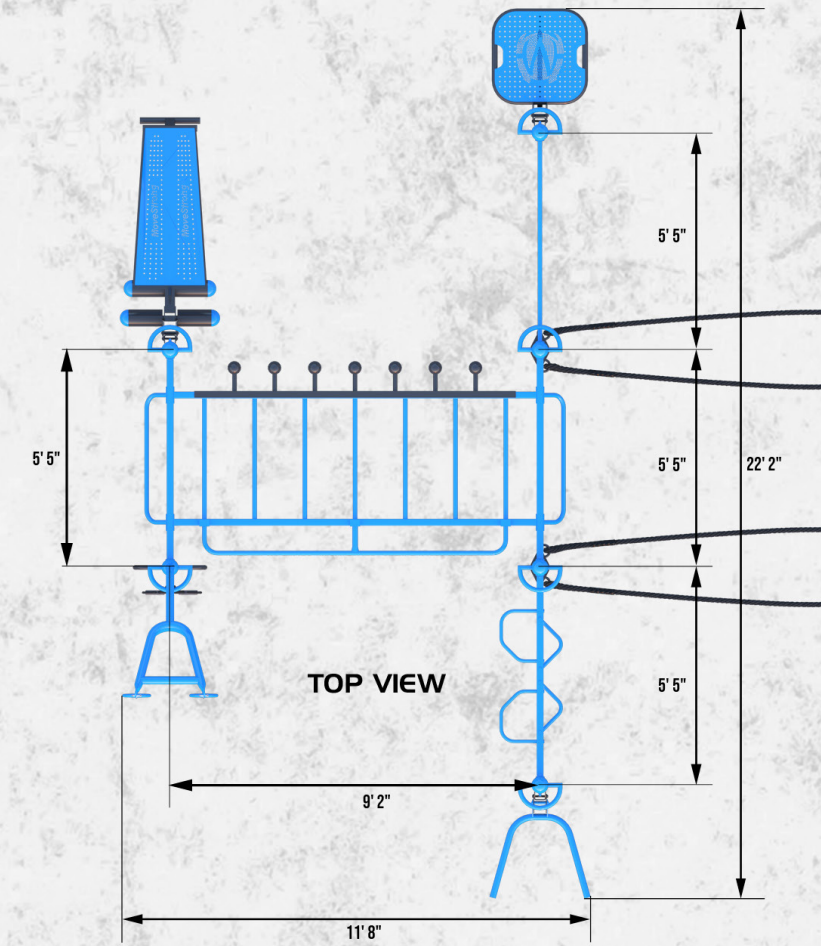
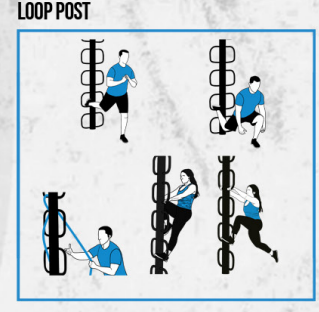
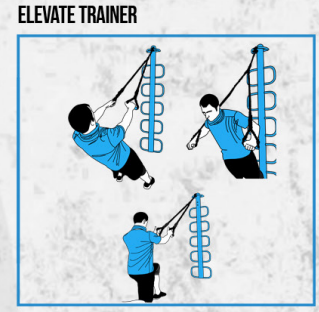
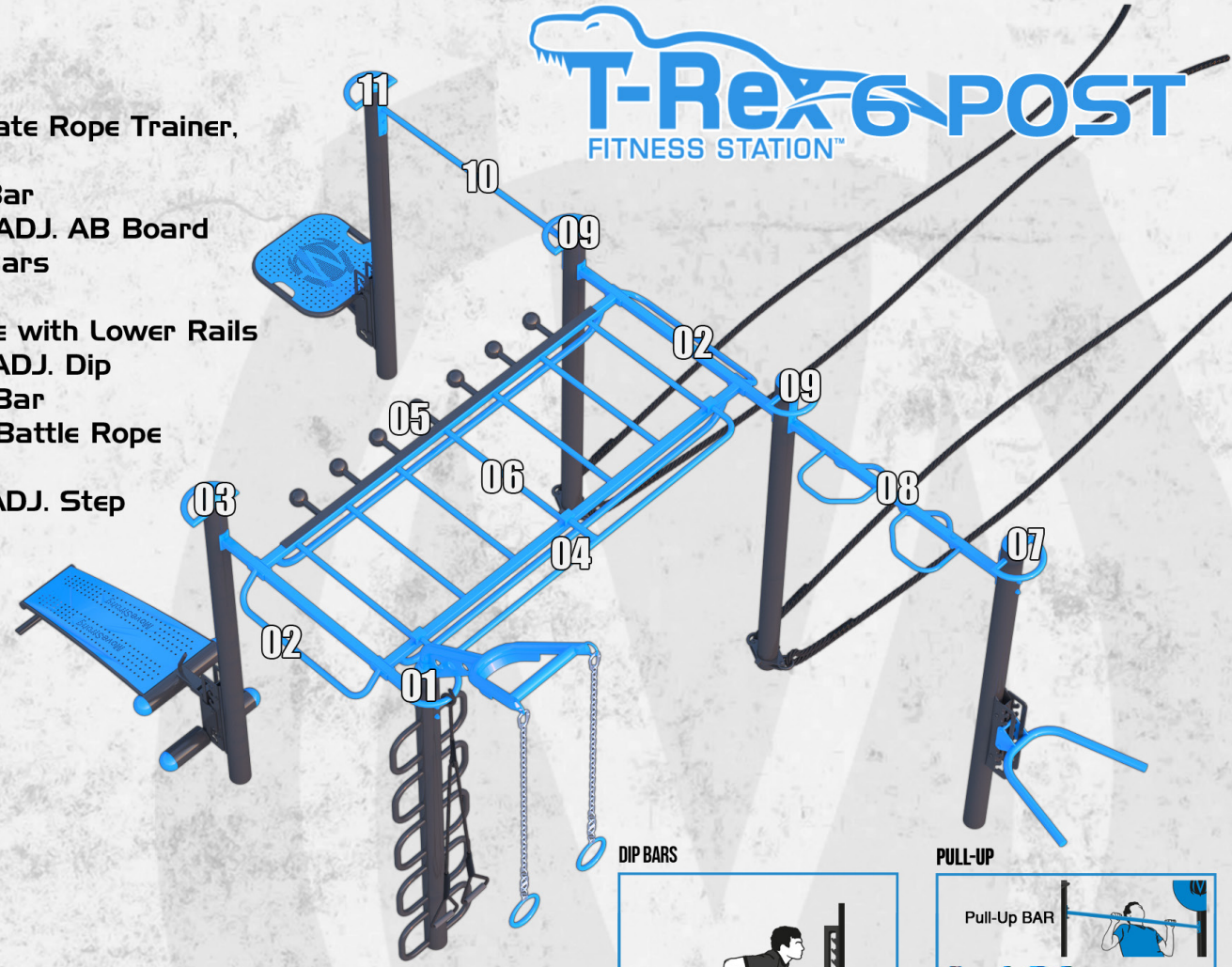

NEW MOBILE TRAINER

MEET YOUR NEW MOBILE TRAINER

1. LOCATE QR CODE
2. SCAN THE QR WITH YOUR PHONE CAMERA
3. WATCH HOW-TO VIDEOS

OR SCAN INSTRUCTIONAL DECALS FOR EVERY FITNESS STATION

<https://movestrongfit.com>

MoveStrong
www.MoveStrongFit.com
MADE IN THE U.S.
Live Life. Move!
USE AT YOUR OWN RISK

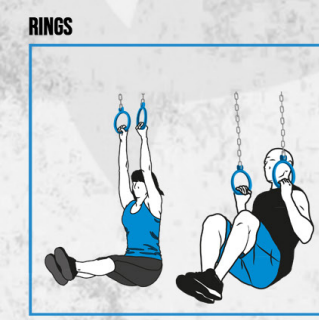
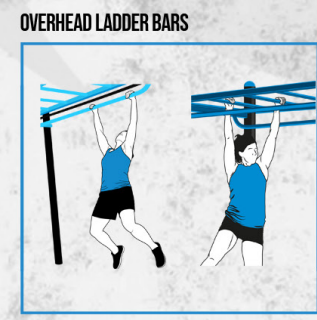

T-Rex 6 POST

FITNESS STATION™

Training Zone

34' 2"

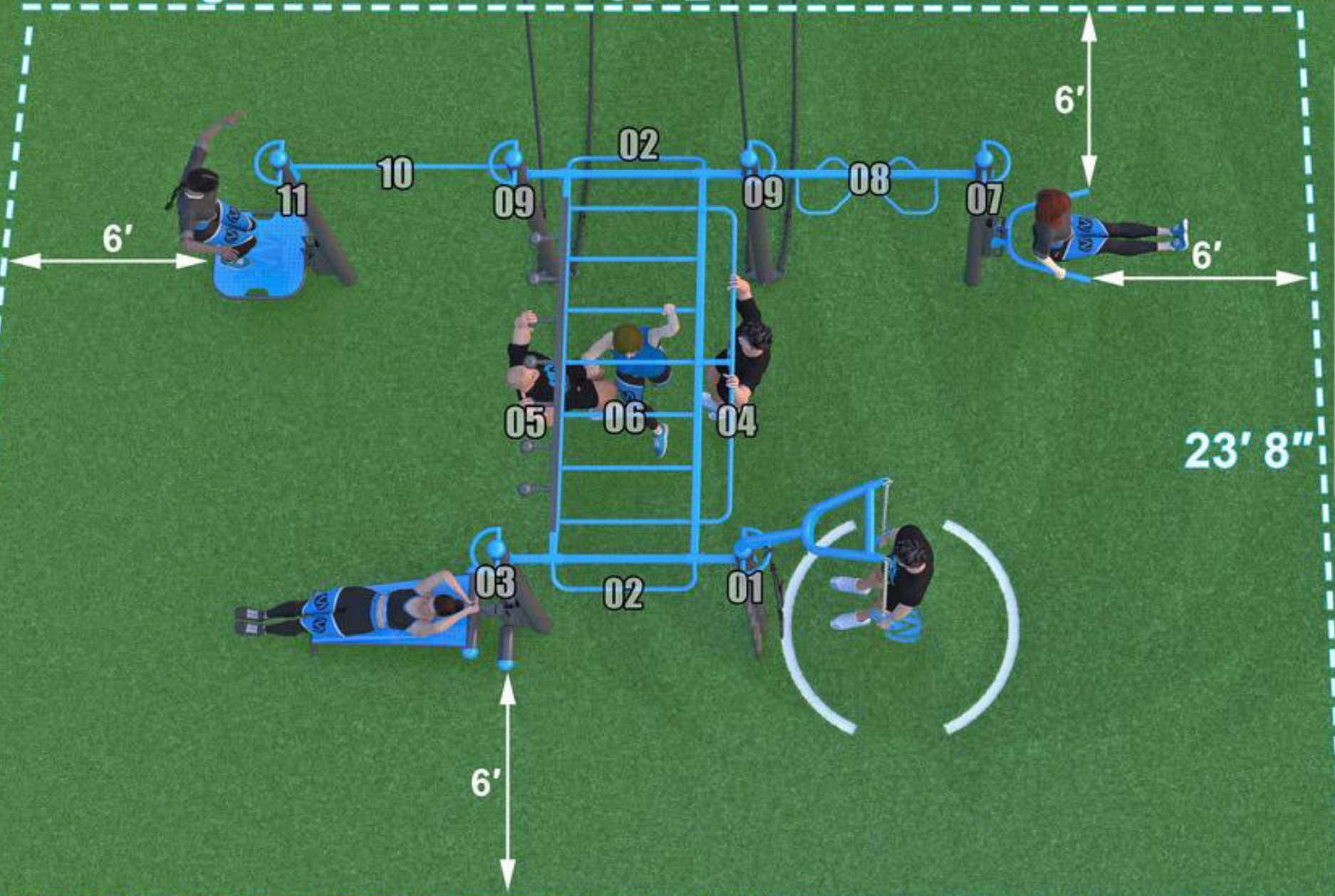

- 01- Loop Post w' Elevate Rope Trainer, Y-Extender & Rings
- 02- Extended Pull-Up Bar
- 03- Standard Post w' ADJ. AB Board
- 04- Side Rail Pull-Up Bars
- 05- Globe Grips
- 06- Monkey Bar Bridge with Lower Rails
- 07- Standard Post w' ADJ. Dip
- 08- Ergo-Grip Pull-Up BAR
- 09- Standard Post w' Battle Rope
- 10- Pull-Up BAR
- 11- Standard Post w' ADJ. Step

