



MoveStrong[®]
Functional Fitness Equipment

STEP UP YOUR FIT GAME

2020-2021 OUTDOOR BROCHURE

Live Life. Move Strong.

“The fastest way to still the mind
is to move the body”

-Gabrielle Roth

5726 MARLIN RD. STE 420 CHATTANOOGA, TN 37411
TOLL FREE (855) 728-8700
MOVESTRONGFIT.COM





TABLE OF CONTENTS

Live Life. Move Strong.

T-REX OUTDOOR FTS 5

4-POST ZIG ZAG	5
4-POST MONKEY BAR BRIDGE	5
5-POST STANDARD	6
T-REX IN-LINE	6
6-POST DOUBLE MONKEY BAR BRIDGE	7
10-POST WITH MONKEY BAR BRIDGE	7
7-POST WITH MONKEY BAR BRIDGE	7
12-POST WITH DOUBLE MONKEY BAR BRIDGE	7

FITGROUND PRODUCTS 11

ZIG-ZAG BALANCE BEAM	12
BALANCE STEPS	12
BATTLE ROPE STATION	13
PLYO-STEPS	13
PUSH-UP/INVERTED ROW BARS	14
ELITE PARALLEL BARS	14
LOW PARALLEL BARS	15
LOW ANGLED CARGO NET	15
CARGO NET	16
A-WALL CLIMBER	16
STALL BARS	17
OVER/UNDER HORIZONTAL POST	17

OUTDOOR OBSTACLE COURSE 18

OC SAMPLE LAYOUTS	20
OC STATIONS	21
HORIZONTAL ROPE CLIMB	22
DUAL ROPE CLIMB	22
20' CARGO NET AND ROPE CLIMB	23
HANGING OBSTACLES	24

CUSTOM / SPECIALTY TRAINING EQUIPMENT 26

LONG STAIRCASE MODEL	25
OBSTACLE STAIRCASE	25
OBSTACLE STAIRCASE WITH RAMP	25
PINNACLE STAIRCASE MODULAR	26
U-STAIRCASE TRAINING OPTIONS	26
TRAVELING RINGS	27
U-STAIRCASE OPTIONAL OPTIONS	27
WARPED WALL	28
SLACKLINING ANCHOR POSTS	29
SLALOM AGILITY POSTS	29

OUTDOOR TRAINING TOOLS 30

DRIVE SLED	30
GLOBE BARBELL	30
SLEDGEBELL	30
FARMER'S WALK LOG	31
FUNCTIONAL TIRE	31
CLIMBING ROPE	31
OUTDOOR RINGS	31

BATTLE ROPES 31

CUSTOM OUTDOOR TRAINING 32

PERFORMANCE SURFACE SOLUTIONS	32
TRAINING PLACARDS & SIGNAGE	33
MOVESTRONG U	34
DESIGN & LAYOUT	35
HAPPY CUSTOMERS	36
HARDWARE & EQUIPMENT WARRANTIES	37



AVAILABLE POST COLORS

VISIT WWW.MOVESTRONGFIT.COM/BYO

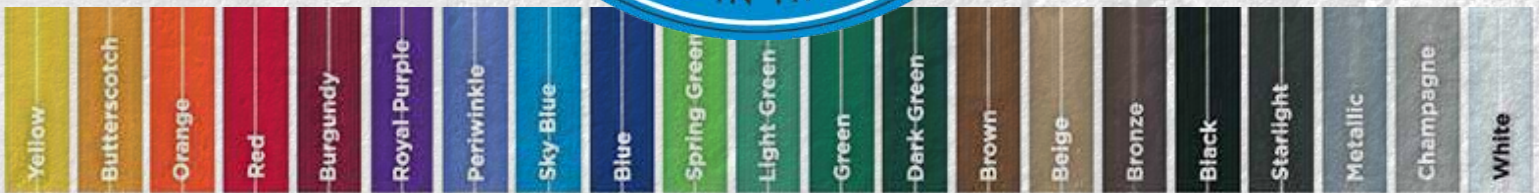

Note: not all colors are available for the T-Rex kickplate, ab bench, step attachment, and the fitground plyo steps. These products are coated with polyurea or pvc coating colors choices: black, gray steel, sky blue, red, dark blue, dark green, and brown.



WEAR PARTS: POLYUREA COATING FOR LONGER DURABILITY AND PROTECTION FROM THE ELEMENTS

OPTIONAL PULL-UP AND DIP BAR POLYUREA COATING



NEW

T-REX ADJUSTABLE DIP PATENT PENDING ADJUSTABLE TRAINING FEATURES DIP, STEP, AB BENCH

04

MOVESTRONGFIT.COM

T-REX OUTDOOR FTS

The MoveStrong T-Rex can be configured in size, shape, and options to fit any space and training needs.



Training Features 4-Post T-Rex Model. See more options below

1. Y-Extender - climbing rope and rings
2. Climber bar extension for horizontal bridge
3. Globe grip side rail - gripe pull-ups and ring toss single medicine ball target
4. Single medicine ball target
5. Kickplate - bodyweight training, anchor points for accessories, medicine ball throws
6. Extended pull-up bar for horizontal bridge
7. Post Extension Hanger
8. Cliff Hanger
9. Loop post - bodyweight training, stretching, anchor points for accessories, rope pulls
10. Battle Rope Anchor - Swivel anchor for
11. outdoor battle ropes

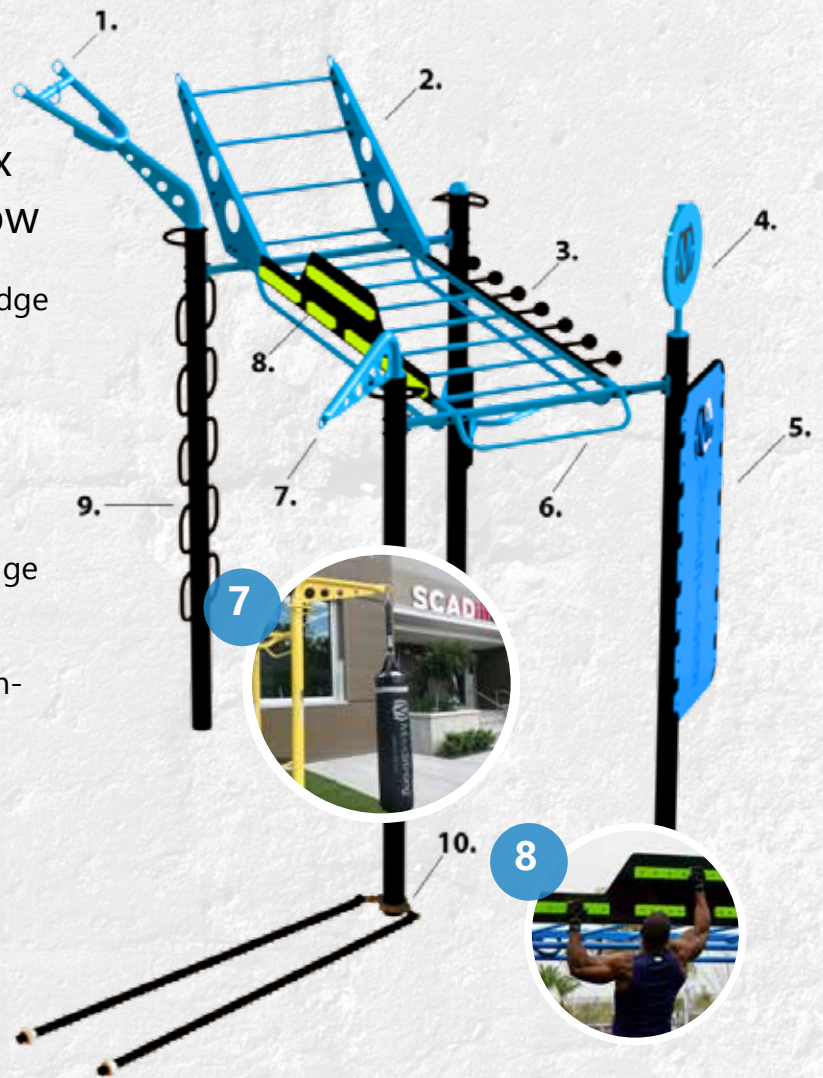

3-POST

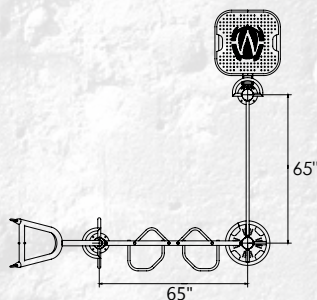

4-POST ZIG ZAG

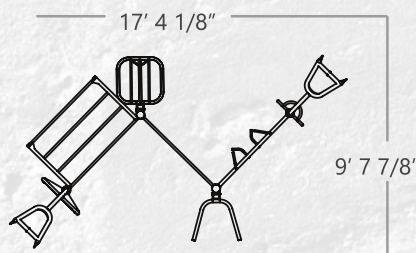

4-POST MONKEY BAR BRIDGE

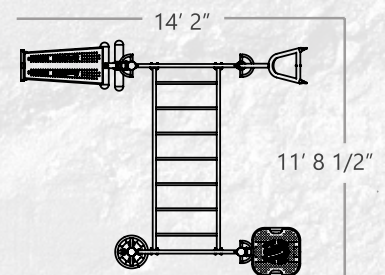



5-POST STANDARD

Y-EXTENDER:
FOR GYM NASTICS RINGS
CLIMBING ROPES

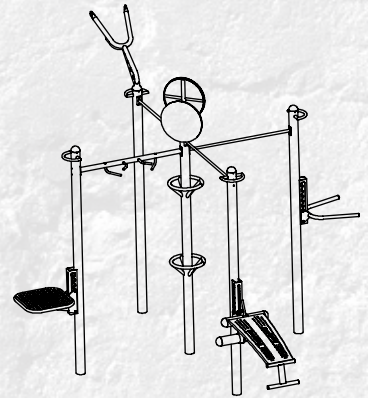
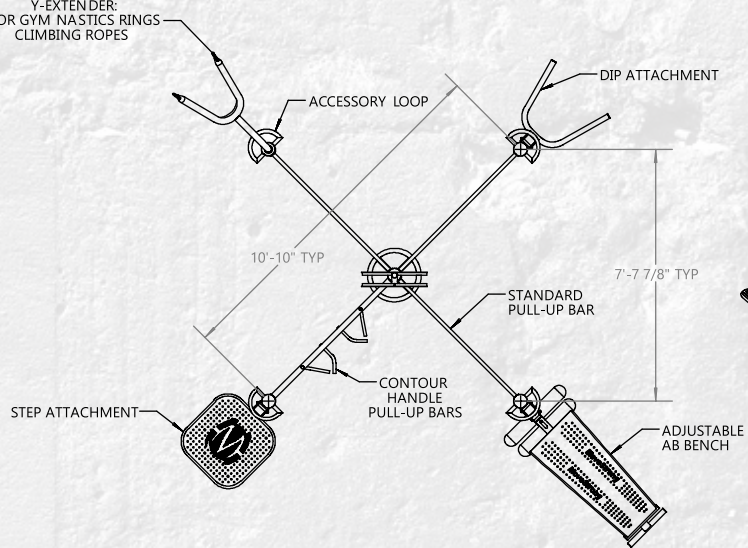

T-REX IN-LINE

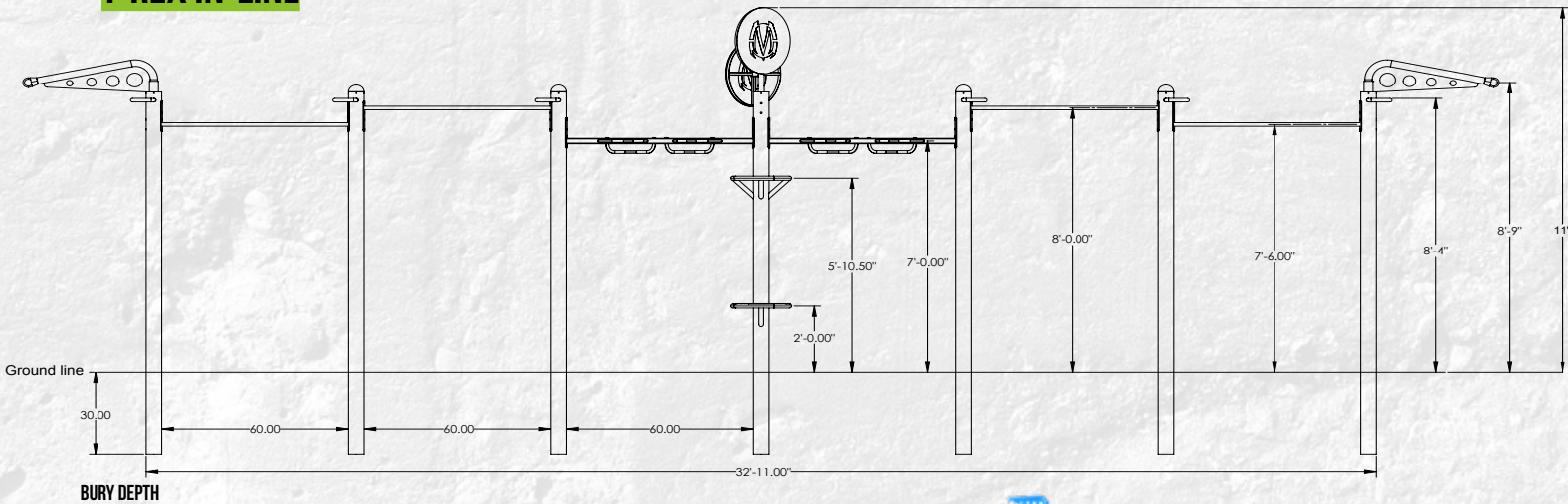

**3 PULL-UP BAR HEIGHTS TO
CHOOSE FROM WHEN INSTALLING**

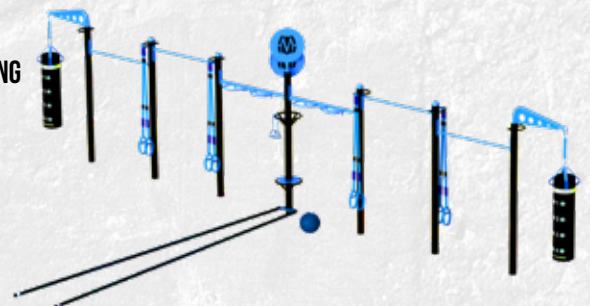

06



VISIT MOVESTRONGFIT.COM OR CONTACT US FOR MORE OPTIONS



6-POST DOUBLE MONKEY BAR BRIDGE

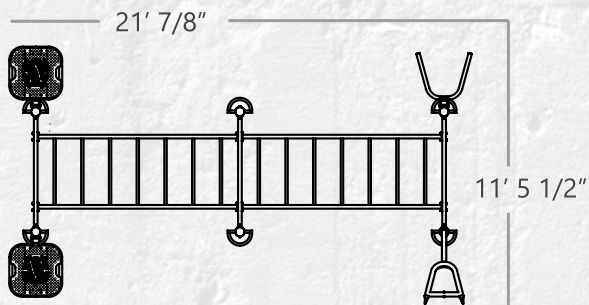

7-POST WITH MONKEY BAR BRIDGE

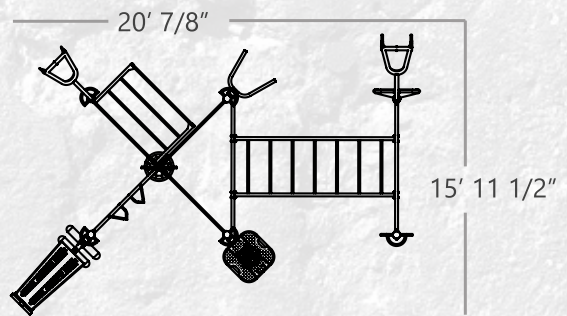

10-POST WITH MONKEY BAR BRIDGE

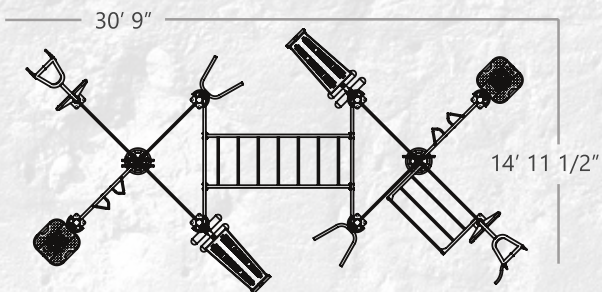

12-POST WITH DOUBLE MONKEY BAR BRIDGE

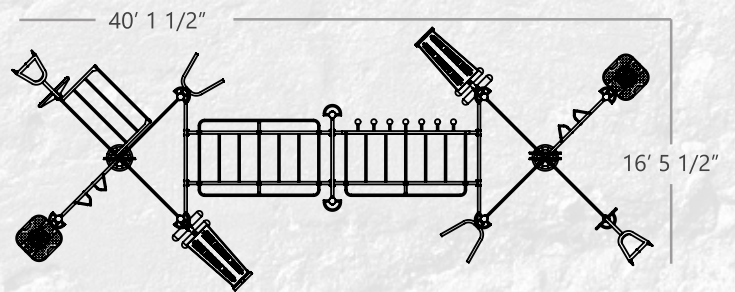

T-REX FTS TRAINING OPTIONS

T-REX FTS 12-POST DOUBLE MONKEY BAR BRIDGE (DIAGRAMS SHOWING OPTIONAL FEATURES)



08



AVAILABLE TRAINING FEATURES

1. Adjustable Step
2. Battle Rope Anchor
3. Dual Medicine Ball Target
4. Rings
5. Adjustable Ab Bench
6. Adjustable Dip
7. Top Loop Post Anchor
8. Horizontal Ladder Bridge
9. Center Post Loop with Step
10. Kick Plate
11. Climber Bars
12. Globe Grip Side Rail
13. Climbing Rope
14. Pull Bar
15. Ergo Grip Pull-Up Bar
16. Side Rail Pull Up Bar



11



13



14



15



10



09

09

THE MOVESTRONG FITGROUND

TAKE FUNCTIONAL FITNESS OUTDOORS!



10

FITGROUND PRODUCTS



customize and build a fitground for your space and training needs. See all the accessories!

Cargo Net with Rope Climb Stations

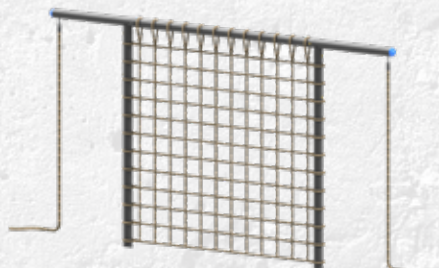

Balance Steps

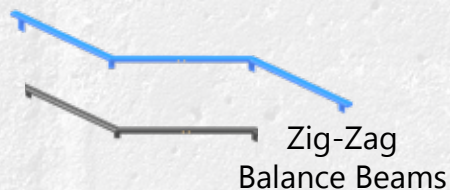

Plyo-Steps



battle rope station



Low Angled Cargo Net

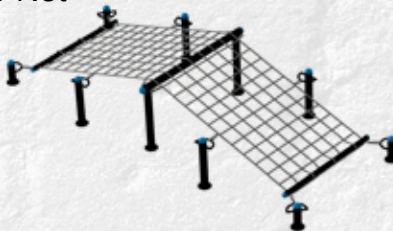

Stall Bars



Over / Under Horizontal Post



Low Parallel Bars

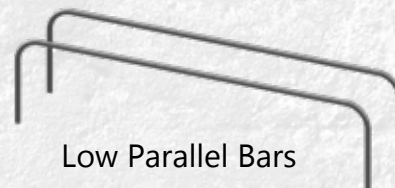

Push-Up / Inverted Row Bars

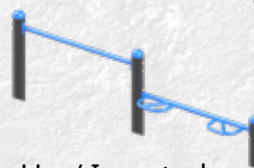

Drive Sled



Elite Parallel Bars

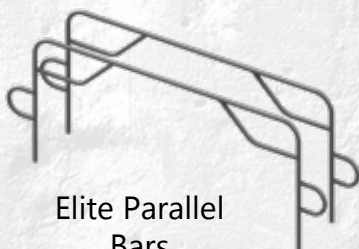

A-Wall Climber



Farmer Logs



SEE MORE FITGROUND
OPTIONS BELOW

ZIG-ZAG BALANCE BEAM

The Zig-Zag Balance Beam allows for many bodyweight exercises to improve balance and stability.

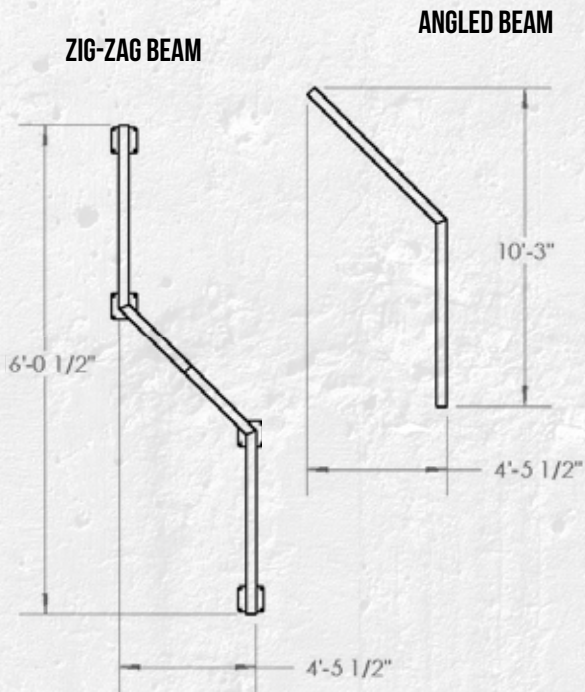

BALANCE STEPS

Focus on balance and agility with the Balance Steps. Configure your FitGround area with different quantities and patterns to fit layout and exercise needs.

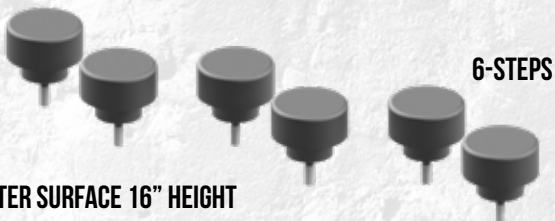

12" DIAMETER SURFACE 16" HEIGHT

Rubber surface step allows for slight tilting for feedback on balance

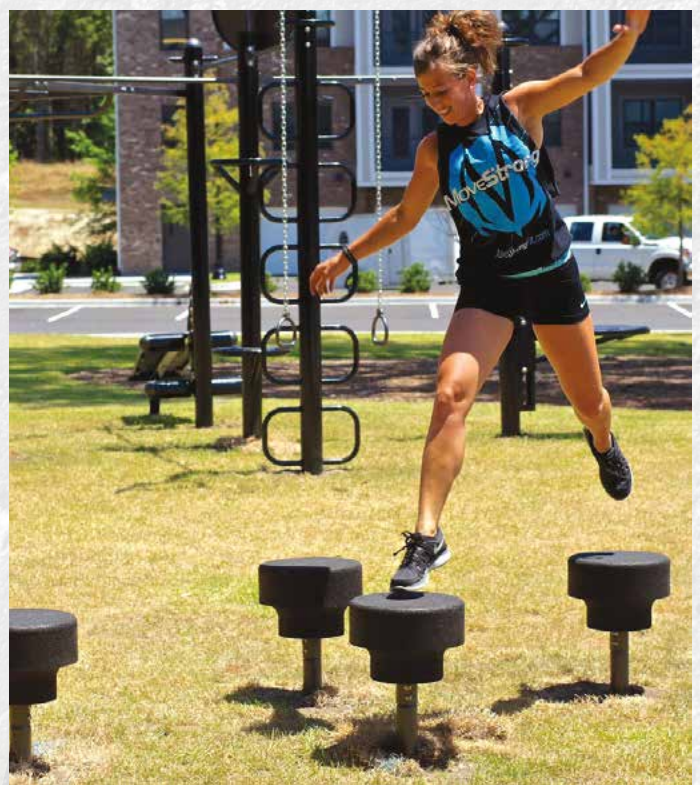

12

BATTLE ROPE STATION

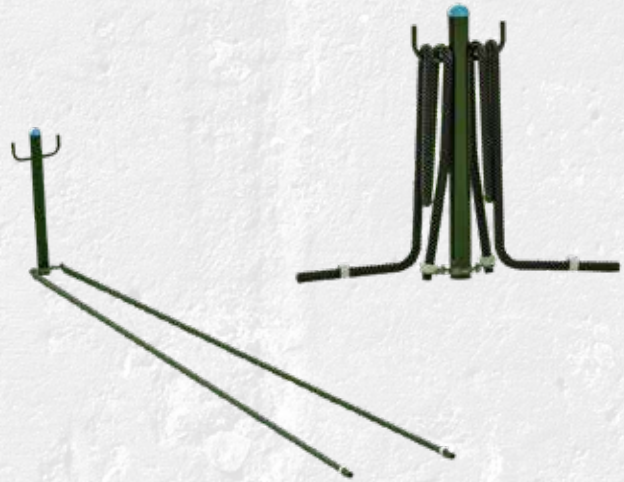

PLYO-STEPS

Varied height Plyo-Steps are great for improving agility, flexibility, power, and for building athleticism.



3 HEIGHTS AVAILABLE 12", 18", 24"



2'-4 5/8" TYP



2'-4 5/8" TYP

PUSH-UP/INVERTED ROW BARS

Build upperbody and core strength with the varied height Push-Up Bars. Two height bars ideal for push-up variations and inverted rows. Lower bar offer varied hand grip positions.

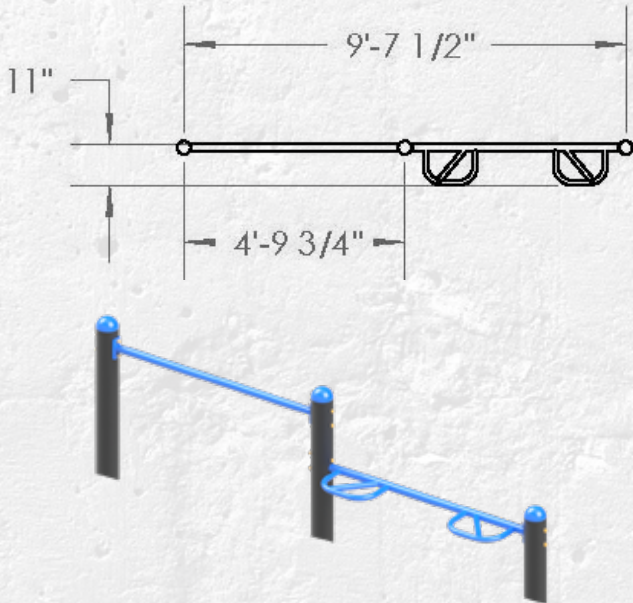

ELITE PARALLEL BARS

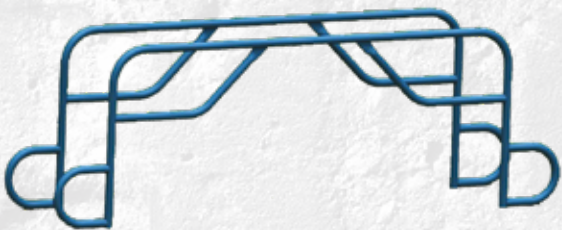
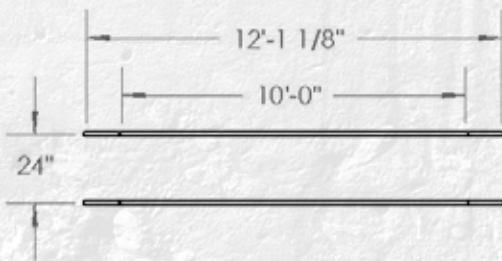



LOW PARALLEL BARS

The Low Parallel Bars are ideal for upper body, agility, and balance exercises.

**10" LENGTH AND 12" HEIGHT.
INQUIRE ABOUT OTHER OPTIONAL SIZES**



LOW ANGLED CARGO NET

Great obstacle course style station with an up-and-over crawl on top of the low height angled cargo net. Develop balance, strength, and coordination skills with this fun challenging obstacle.

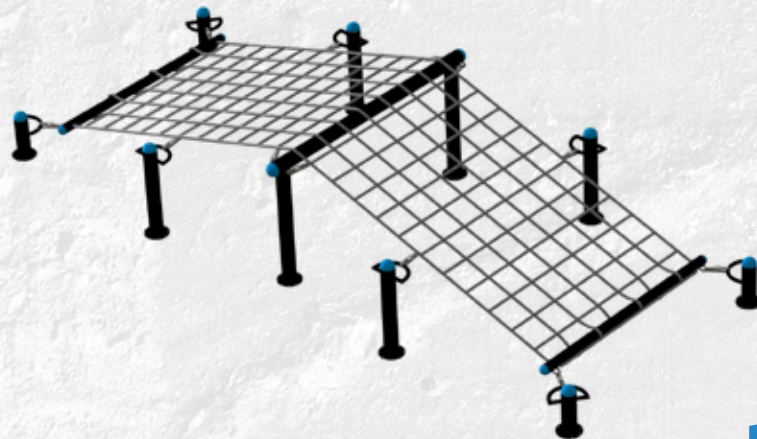

**18'4" L X 8' W X 4'2" H
CONTACT US FOR CUSTOM SIZES**

CARGO NET

Use for functional fitness, climbing, bodyweight, and obstacle course training. Offers two optional rope climb stations as well.

10' CARGO NET FRAME HEIGHT.
INQUIRE ABOUT OTHER HEIGHT OPTIONS.

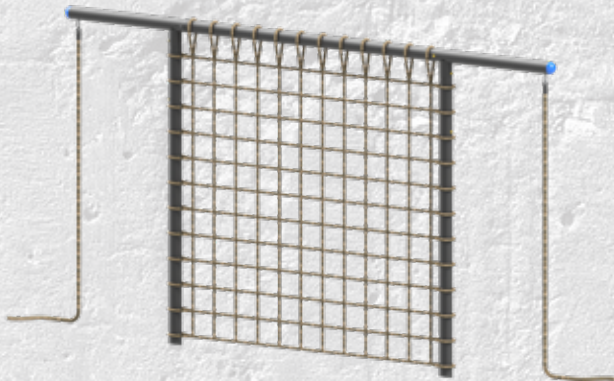
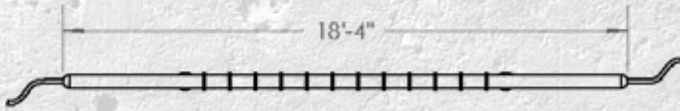

A-WALL CLIMBER

The A-Wall Climber is a great FitGround addition to create a challenging up and over climb. Climbing rope to grasp and assist on climb up and over the step angle wall.



8' OVER HEIGHT. INCLUDES CENTER GRAB ROPE.



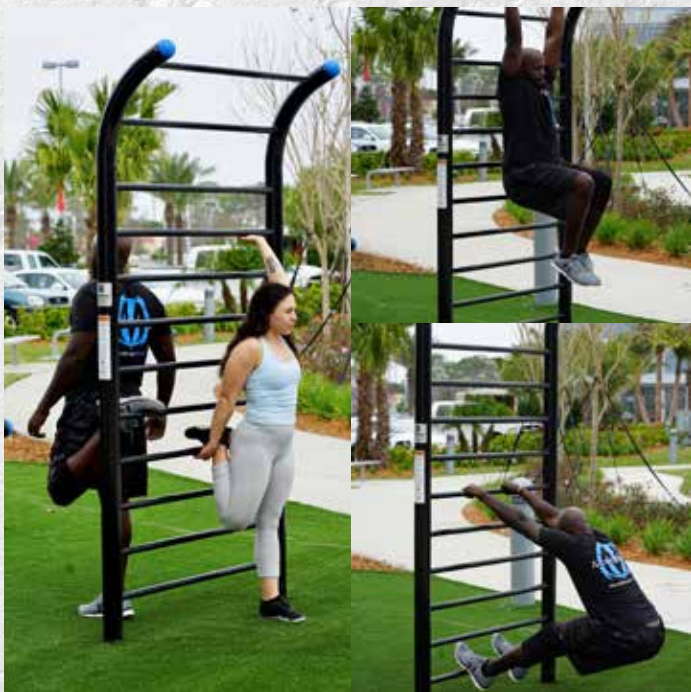

STALL BARS

Dedicated flexibility and stretching station. Varied height rungs to assist in flexibility and bodyweight exercises. Arched top bar for hangs and pull-up variations.

STALL BAR DIMENSIONS ARE 4' WIDE X 8' TALL

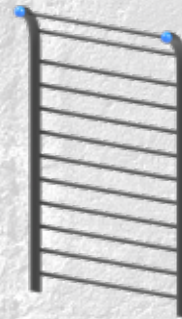

OVER/UNDER HORIZONTAL POST

The Over/Under posts are great for agility, balance, and strength training.

AVAILABLE IN 3 HEIGHT OPTIONS: 24", 36", 48"

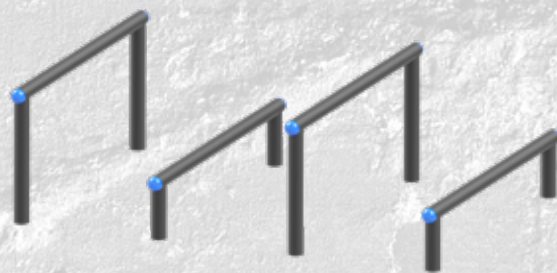
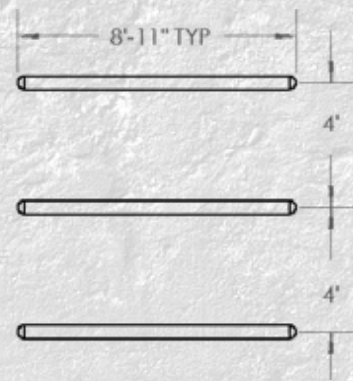

OUTDOOR OBSTACLE COURSE



BUILD CONFIDENCE AND TEAMWORK

Obstacle course training is an excellent way to gain confidence as users get stronger and more confident with each run through the course. Work together as a team to encourage others and compete against each other for friendly competition and bonding as a group. A great social activity since others will experience all the same challenges together. Use obstacle course training to build stronger friendships and develop a support system among teams and co-workers.

IMPROVE ENDURANCE, STAMINA, AND FUNCTIONAL STRENGTH

OC Training is a great way to get heart healthy with cardiovascular exercise, build real usable functional strength and athletic muscle mass while and burning body fat all at the same time.

BREAK THE BOREDOM

break the normal gym routine with some fresh air and MoveStrong OC Training. A fun challenging way to incorporate new workouts sure to help break the norm of traditional machine gym workouts that will no doubt yield new results in your athletic, physical, and body composition results!

INCREASE FLEXIBILITY & AGILITY WITH IMPROVED BALANCE

Climb, crawl, run, jump, balance, and swing your body through a variety of obstacles. Move in manners the body was intended! You will quickly become more agile and improve those athletic skills with obstacle training. Over time, you'll get better and more energy efficient with improved work capacity as you learn how to overcome obstacles more efficiently and preserve energy to make it all the way across the finish line without running out of steam.



PUT PHYSICAL CHALLENGE AND COMPETITION TO THE TEST WITH THE MOVESTRONG OBSTACLE COURSE! CUSTOMIZE AND BUILD A COURSE TO FIT YOUR SPACE AND TRAINING NEEDS.

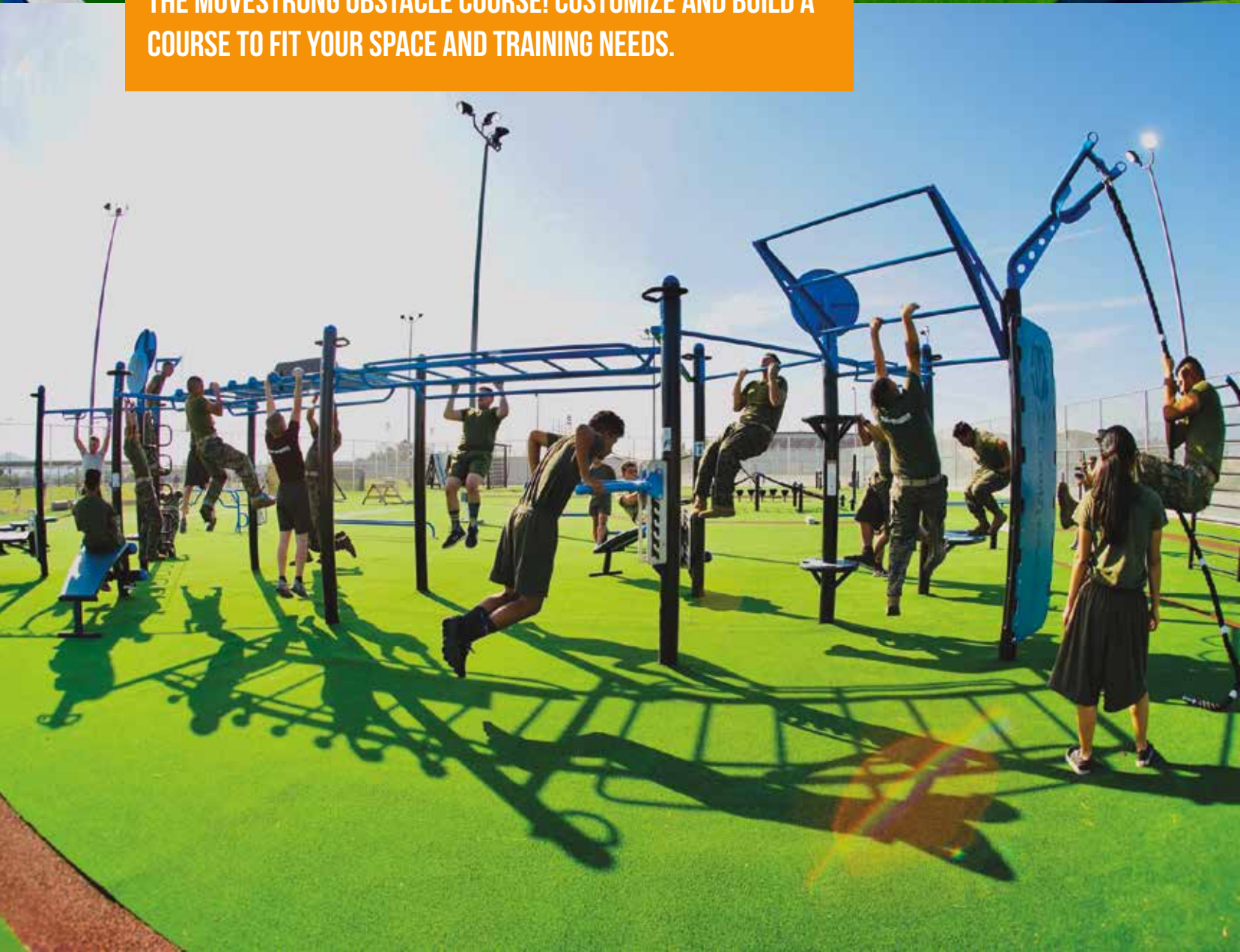

OC SAMPLE LAYOUTS



COMPLETE OBSTACLE COURSE

OC STATIONS

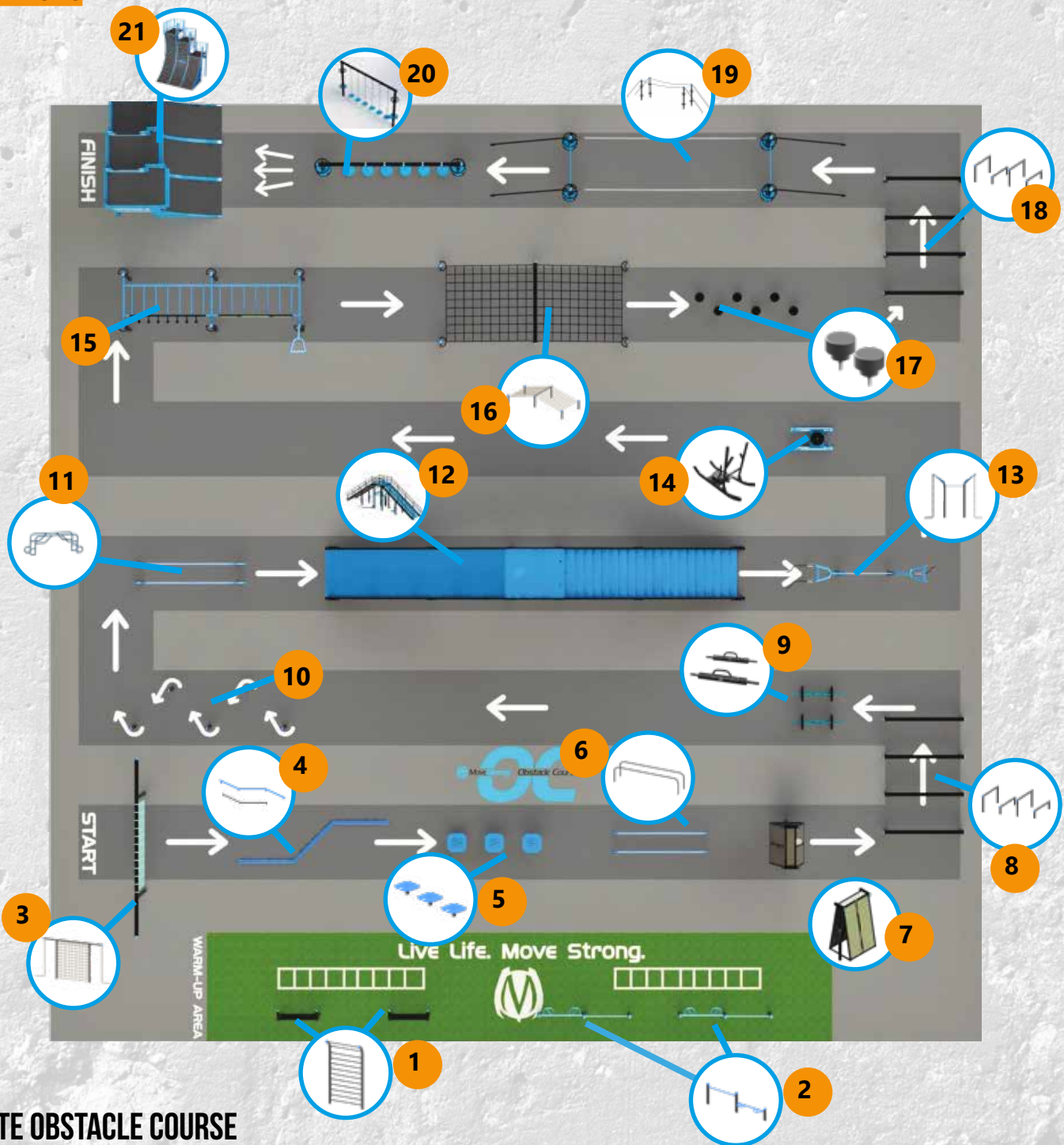

COMPLETE OBSTACLE COURSE

- | | | |
|--------------------------------|----------------------------------|---------------------------------------|
| 1. Stall Bars | 9. Log Carry | 17. Balance Steps |
| 2. Push-Up/Inverted Row Bars | 10. Slalom Agility Posts | 18. 36" & 48" Over/Under Agility Post |
| 3. Cargo Net Rope Climb | 11. Parallel Bar Upper Body Walk | 19. Horizontal Rope Climb |
| 4. Zig-Zag Balance Beam | 12. Obstacle Staircase | 20. Swinging Balance Steps |
| 5. Plyo Step Jumps | 13. Rope Climb Station | 21. Triple Warped Wall |
| 6. Low Parallel Bar | 14. Drive Sled Push | |
| 7. A-Wall Climber | 15. 6-Post T-Rex | |
| 8. 24" Over/Under Agility Post | 16. Low Cargo Net Climb | |

HORIZONTAL ROPE CLIMB



20' HORIZONTAL ROPE TRAVERSE

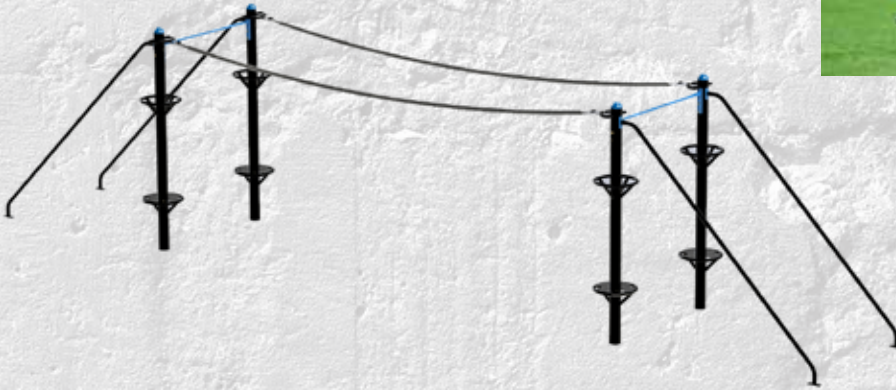

DUAL ROPE CLIMB

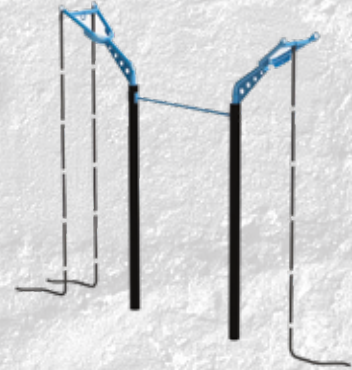
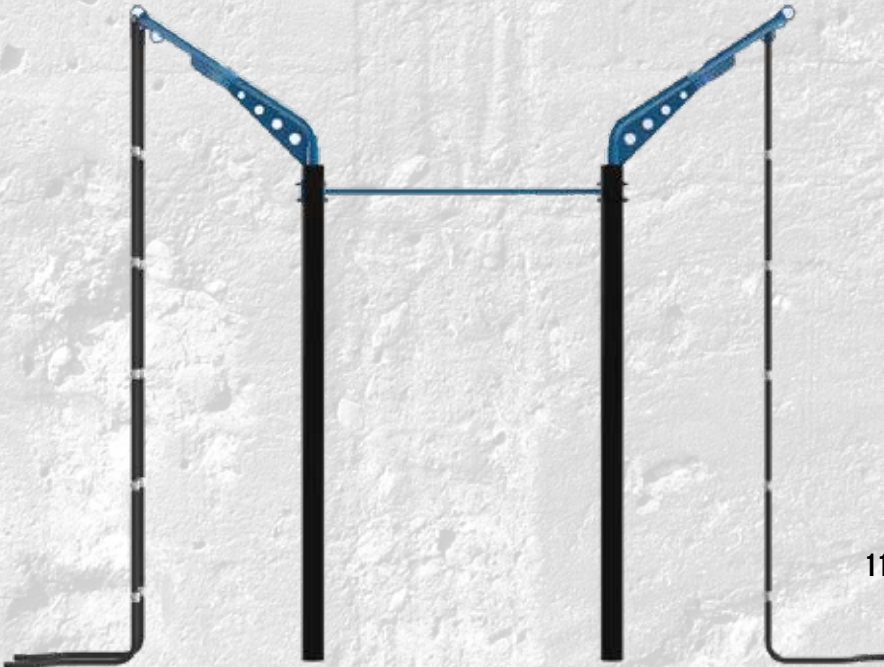

11' DUAL OR SINGLE ROPE CLIMB WITH CENTER HANG BAR

20' CARGO NET AND ROPE CLIMB

20' ROPE CLIMB OPTIONS AVAILABLE

NEW

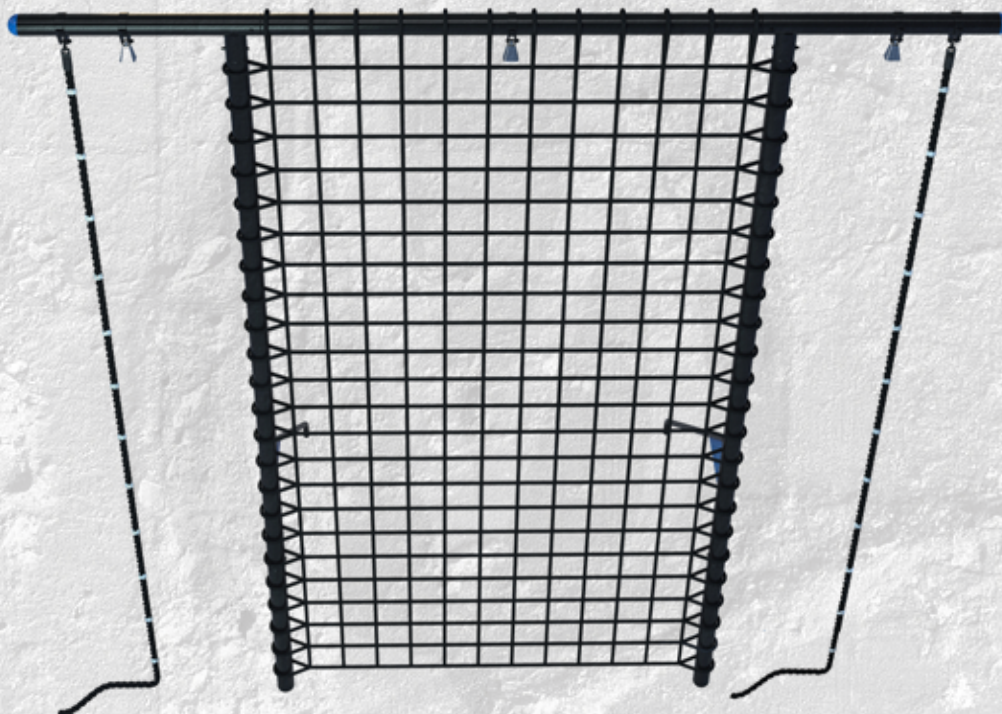
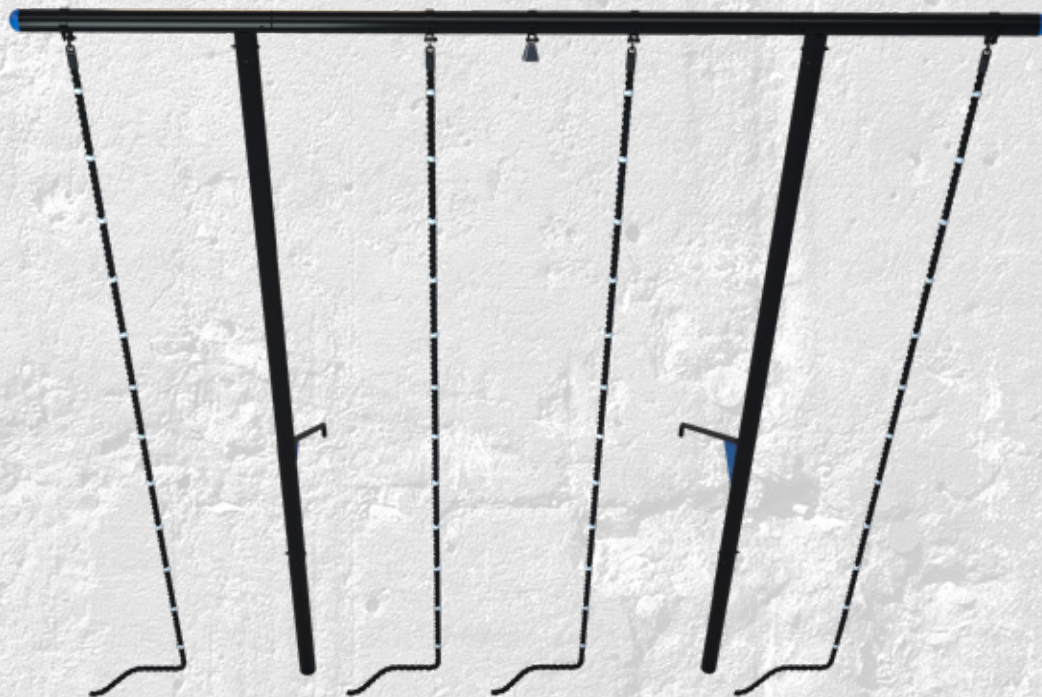

HANGING OBSTACLES



HANGING BALANCE

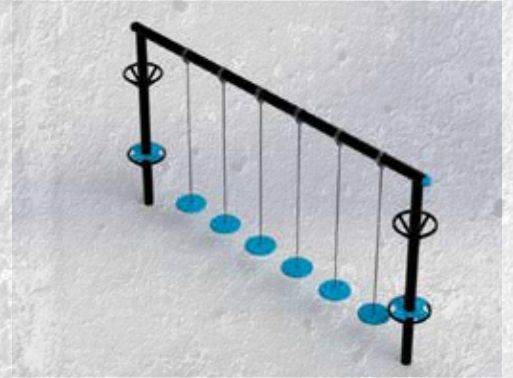

DOWEL GRIPS



RING TRAVERSE

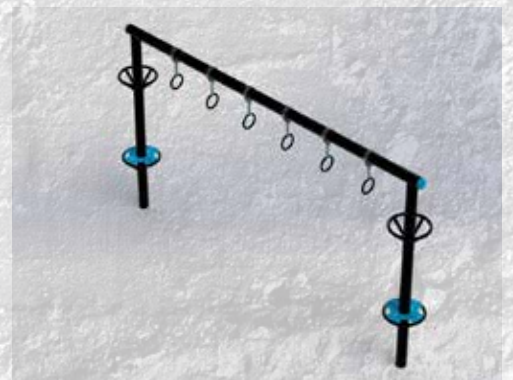

MoveStrong®

Staircase & Ramp

Functional & Obstacle Course Training



LONG STAIRCASE MODEL

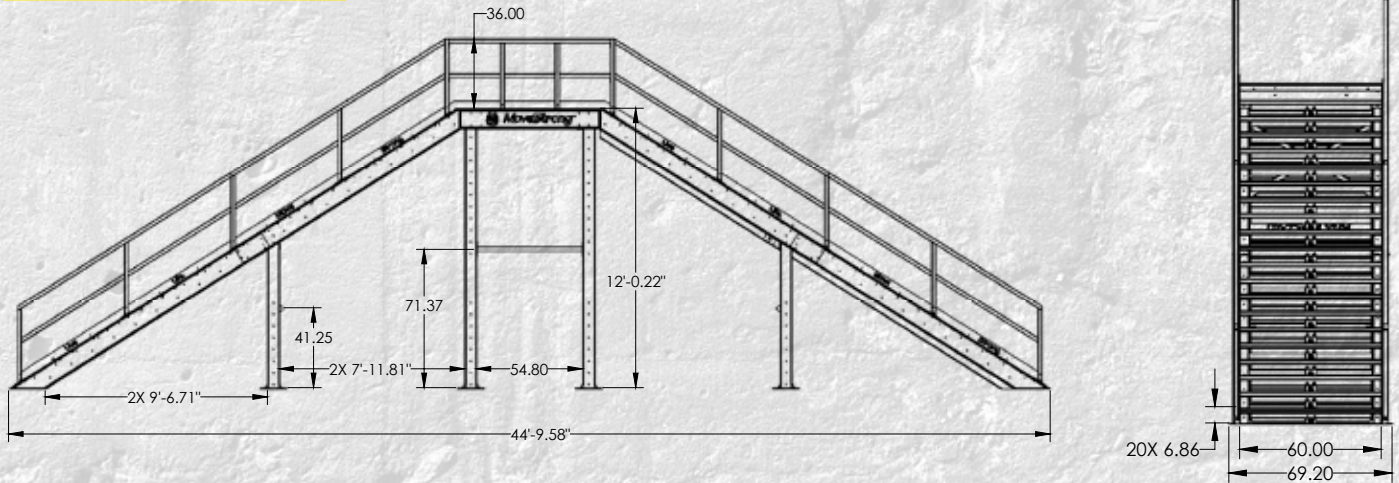

OBSTACLE STAIRCASE

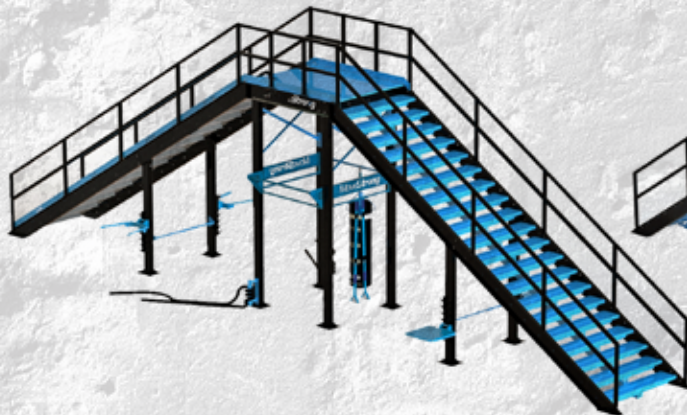

OBSTACLE STAIRCASE WITH RAMP

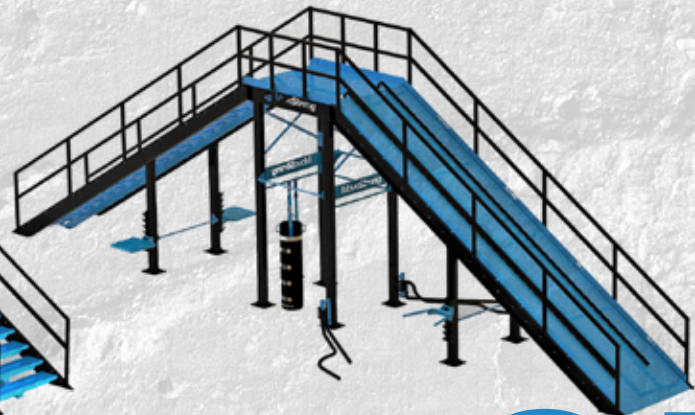

CONFIGURE WITH OPTIONAL TRAINING FEATURES UNDER STAIRCASE

*DESIGN PATENT PENDING

MOVESTRONGFIT.COM

25

PINNACLE STAIRCASE MODULAR DESIGN

Customize with obstacles on all 4- sides of the Long Staircase. Warped Wall and cargo nets shown.



CUSTOM / SPECIALTY TRAINING EQUIPMENT

NEW

Build a specialty training solution to suit your training program needs.

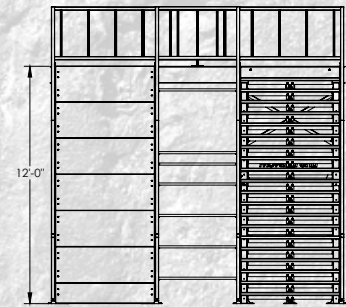
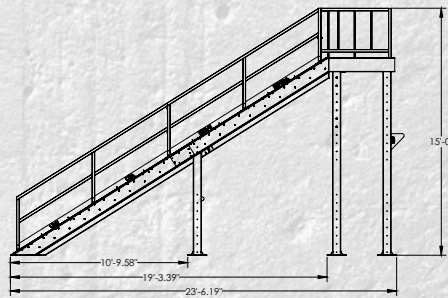
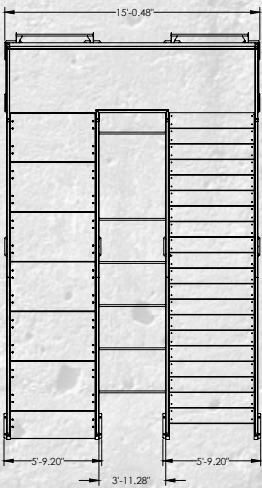

U-STAIRCASE TRAINING OPTIONS

1. KickPlate w/ Medicine Ball Target and Storage
2. Squat Stands
3. Pull-Up Bar With Medicine Ball Logo Plate
4. Dual Height Pull-Up Bar
5. Battle Rope Anchor
6. Push-Up Bar
7. Climbing Rope
8. GRT (Ground Rotational Trainer)



U-STAIRCASE OPTIONAL OPTIONS

- 9. Adjustable Dip
- 10. Adjustable Step
- 11. Diamond Medicine Ball Target
- 12. Olympic Plate Storage

TRAVELING RINGS

WANNA FLY!?! OUR TRAVELING RINGS ARE DESIGNED TO CREATE THAT FEELING!

TRAVELING RINGS - STANDARD

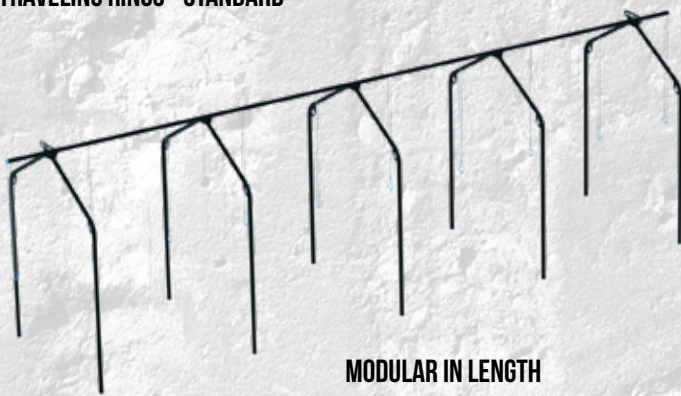

MODULAR IN LENGTH

TRAVELING RINGS - ELITE C

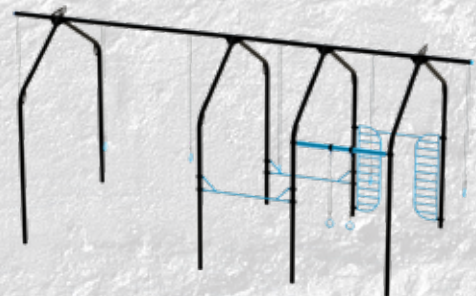

MODULAR IN LENGTH AND TRAINING FEATURES

Elite-C: Additional Calisthenics Training Options Shown - Pull-Up Bars, Push-Up Bars, Gymnastic Rings, and Ladder Bars

WARPED WALL



8' WALL



TRIPLE WARPED WALL

- 8', 12', and 14' Warped Walls
- Backside Training Features and Options
- Optional Top Safety Rails



CUSTOM BACKSIDE CARGO NET OPTION

SLACKLINING ANCHOR POSTS



SLALOM AGILITY POSTS

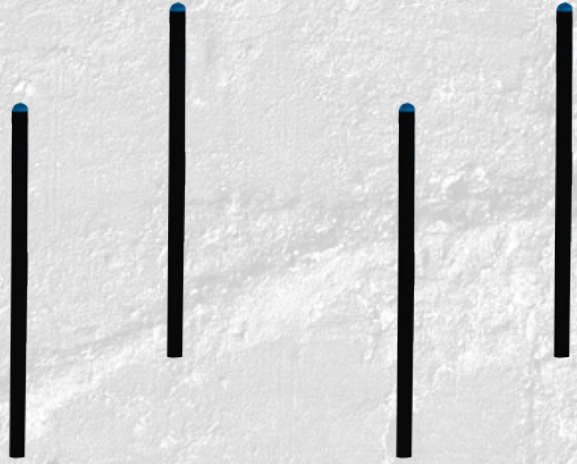
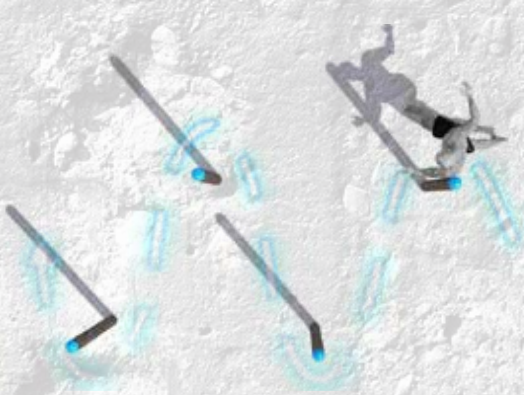

OUTDOOR TRAINING TOOLS



DRIVE SLED

Do more with a Drive Sled for strength and conditioning! Develop power by pushing and pulling high and low, forwards and backwards, fast and slow, to add variety and make a sled workout more challenging and to shred fat while improving conditioning.

GLOBE BARBELL

Specifically designed for year round outdoor use, our fillable Globe Barbell is an excellent strength tool to incorporate barbell lifts and old time strongman exercises! Each globe can be filled with sand or shot to desired weight. The tough exterior finish and texture grip allow for durability and many years of use both indoor and outdoors. A great training tool addition to our FitGround outdoor product line!

SLEDGEBELL

Specifically designed for year round outdoor use, our fillable SledgeBell is an excellent strength tool. An incredible total body conditioning tool allows you to swing, hammer, balance, lunge, chop, and throw it! Designed to use for sledgehammer strength and conditioning exercises with a tire as well as performing a variety of swing and chop patterns to help mobility, core strength, and stability while engaging the entire body.



*Weight plates not included.

FARMER'S WALK LOG

Designed for outdoor use in the FitGround, our Farmers Walk Logs are a fun way to build strength and endurance for loaded carries. Add weight in the fill hole of the log and/or traditional Olympic weight plates on the end holders.



CLIMBING ROPE



OUTDOOR RINGS



BATTLE ROPES



FUNCTIONAL TIRE

80kg & 120kg size functional training tires for outdoor use. Ground anchors available to keep tires in fixed area to prevent removal.

CUSTOM OUTDOOR TRAINING

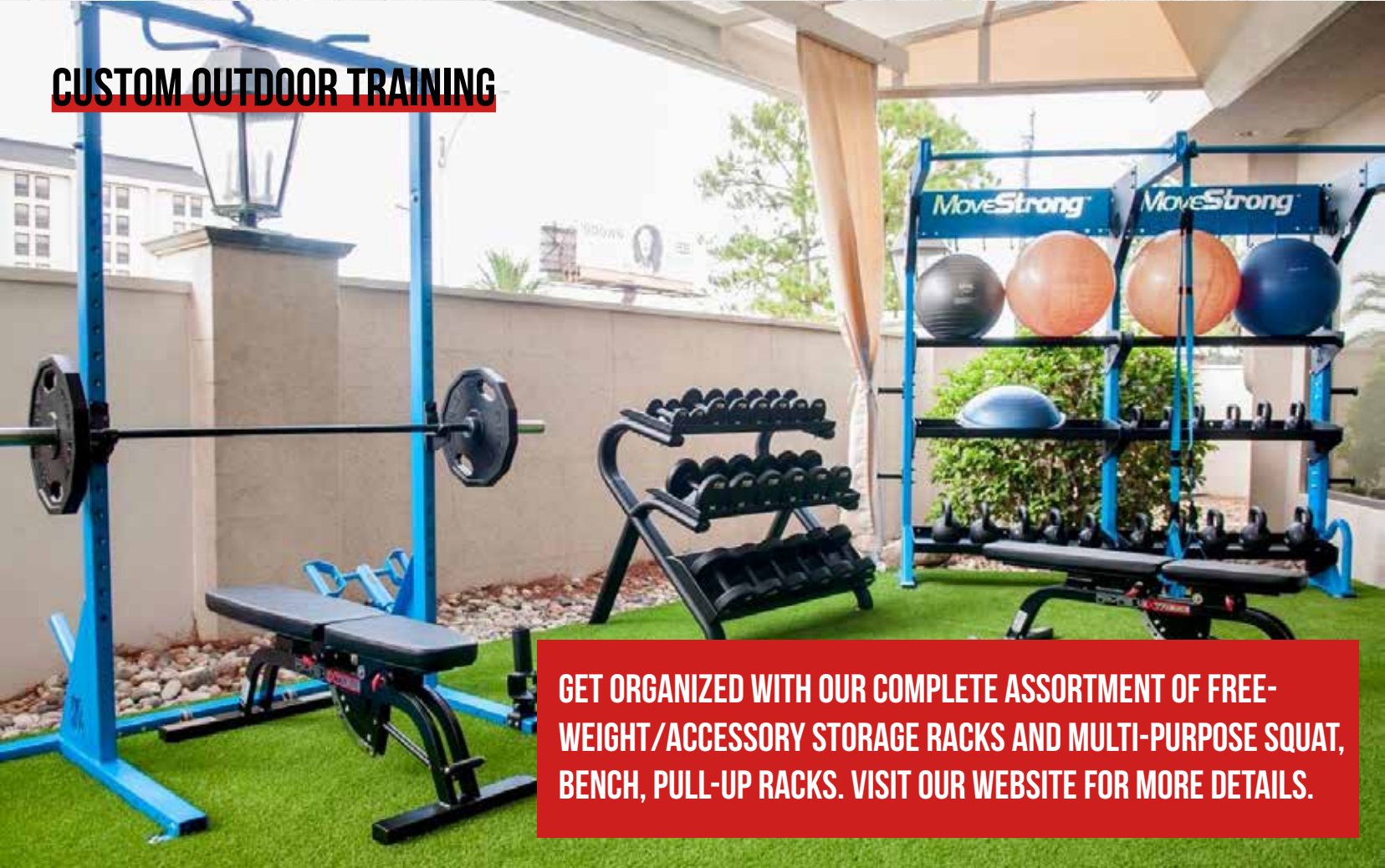

GET ORGANIZED WITH OUR COMPLETE ASSORTMENT OF FREE-WEIGHT/ACCESSORY STORAGE RACKS AND MULTI-PURPOSE SQUAT, BENCH, PULL-UP RACKS. VISIT OUR WEBSITE FOR MORE DETAILS.

PERFORMANCE SURFACE SOLUTIONS



CUSTOMIZABLE PERFORMANCE SURFACE SOLUTIONS. WE OFFER PLANNING, DESIGN, AND SUPPLY OF SPECIALTY FITNESS SURFACING AND SAFETY PADDING BASED ON SPACE, TRAINING NEEDS, AND BUDGET. VISIT OUR WEBSITE FOR MORE DETAILS.

32

MOVESTRONGFIT.COM

TRAINING PLACARDS & SIGNAGE



**CUSTOM SIGNAGE AVAILABLE.
INQUIRE FOR OPTIONS**

Elite Parallel Bars

Angle Push-up

1. Grab 45 degree angled bars
2. Maintain straight body position
3. Lower body towards bars and return to length position



Recline Pulls

1. Grasp both angled bars under parallel back facing ground



Zig-Zag Balance Beam

1. Step up on beam and walk entire length while maintaining balance
2. Continue forwards and backwards for challenge



Stall Bars

Hamstring Stretch

1. Facing bars place one foot on rung at desired height
2. Maintain straight leg as you reach forward to a comfortable stretch position



Quad Stretch

1. With back facing bars lift one leg and place top foot on rung at desired height
2. For more of a challenge, increase stretch by grabbing bars over head





USE AT YOUR OWN RISK: Exercise instructions are for informational purposes only. It is your responsibility to evaluate your own physical condition and determine whether to perform, use or adapt any of this exercise information. Any result in injury. By voluntarily undertaking any exercise displayed, you assume the risk.



USE AT YOUR OWN RISK: Exercise instructions are for informational purposes only. It is your responsibility to evaluate your own physical condition and determine whether to perform, use or adapt any of this exercise information. Any result in injury. By voluntarily undertaking any exercise displayed, you assume the risk.



USE AT YOUR OWN RISK: Exercise instructions are for informational purposes only. Consult a physician before performing any exercise program. It is your responsibility to evaluate your own physical condition and determine whether to perform, use or adapt any of this exercise information. Any result in injury. By voluntarily undertaking any exercise displayed, you assume the risk of any resulting injury.

INSTRUCTIONAL PLACARDS AVAILABLE FOR DEMONSTRATING USAGE FOR EACH STATION.

MOVESTRONG U



OUR COLLECTIVE OF RESOURCES IS AT YOUR DISPOSAL WITH MOVESTRONG U. LEARN FROM THE BEST AND PICKUP TIPS AND TRICKS FOR POWERFUL, FUNCTIONAL MOVEMENTS THAT WILL HELP YOU LIVE LIFE AND MOVE STRONGER EVERY DAY, TEACH BETTER EVERY DAY, AND MAKE THE MOST OF YOUR MOVESTRONG EQUIPMENT.

CUSTOMER VIDEO LIBRARY

Created for our customers to have instant access to 100's of MoveStrong™ product videos. Browse the video library to find exercise visuals per product, tips, workouts, promotional, and installation videos on many MoveStrong™ products.

CURRENT WORKSHOPS

Our hands-on courses teach the principles of functional strength/mobility, core stability, and biomechanics of human movement to maximize performance. For beginners to fitness professionals.

MOVE OF THE DAY

Pickup training tips and tricks of the trade with our extensive library of MoveStrong moves. For added benefits, subscribe to our Video Library to extend your knowledge base.

TRAINING EVENTS

Learn how to use the equipment, teach clients to use the equipment and make the most of your investment at our MoveStrong Training Events. You can even earn continuing education credits with some of our classes from leading accredited educators like ACE, NASM, and NSCA.



DESIGN & LAYOUT

Let our team assist with design and layout based on your space and needs. We offer surfacing recommendations for a safe and enjoyable FitGround. Customize with the exercise options desired to create your own station to accommodate different users' fitness and skill levels. Ideal for fitness bootcamps, group training classes, schools, obstacle courses, parks, military, or just a cool backyard adult fitness jungle gym!

Original Design

Final Build

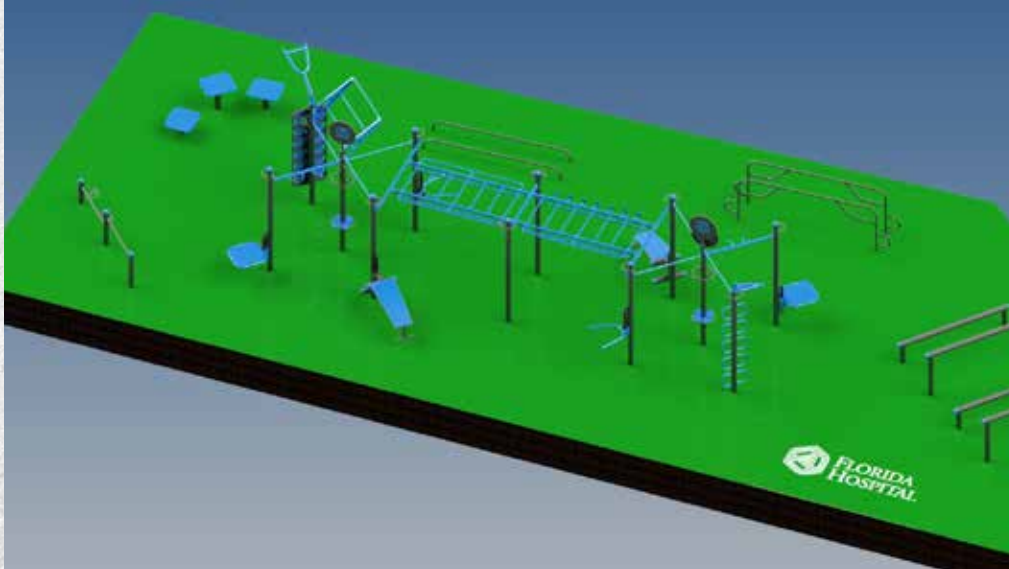

HAPPY CUSTOMERS

Visit Our Website For More Customer References and Pictures

Educational Institutions

- NC State University
- Oakwood University
- Vanguard University
- Fontana Unified Schools
- Bergen County Academies
- Soddy Daisy Middle School
- Ole Miss University
- Santa Clara University
- Savannah College of Art & Design
- Southern Illinois University
- Pitt University
- Purdue University

Military and First Responders

- Fort Polk AB
- Patrick AFB
- Robins AFB
- Columbus AFB
- US Coast Guard Training Center Yorktown
- New Hanover County Sheriff's Department
- Montgomery County Law Enforcement Training Center

Religious Community Centers

- Hagerstown YMCA
- Tri-County YMCA
- Tampa YMCA
- Cincinnati YMCA
- Bridgewater JCC

Municipality / Parks and Recreation

- City of Bartlesville
- City of Castle Rock
- City of Round Rock
- Park City
- Pompano Beach

Corporate Wellness

- Calera
- Pfizer

Community Living

- Oasis
- The Haven
- Eagle Crossing

Fitness Centers / Health Clubs

- Ellis Athletic Center
- Onslow Fitness
- Fitness 1440
- In-Shape
- Club EZ Fit
- Banks Dee Sports Club
- Steel Fitness Health & Wellness
- Mountain Valley Fitness & Health
- Retro Fitness
- O2 Fitness

Fitness Centers / Health Clubs

- Peninsula Papagayo Costa Rica
- Crown Plaza Baton Rouge
- LOCALE Cayman Islands

HARDWARE & EQUIPMENT WARRANTIES



OUTDOOR FITNESS EQUIPMENT WARRANTY

Applies to all MoveStrong equipment designated and specifically manufactured for year round outdoor use.

MoveStrong provides a fifteen-year warranty on metal decks, pipes, rails, loops, and rungs; a lifetime limited warranty on upright posts; and a one-year warranty on the powder coating. These warranties cover damage due to failure or corrosion of metal parts that cause the product to become structurally unfit for its intended use. The lifetime warranty refers to the life of the product and covers the product under normal use and proper maintenance.

LIFETIME LIMITED WARRANTY ON HARDWARE

MoveStrong provides a lifetime limited warranty against structural failure due to breaking or shearing which causes the product to become structurally unfit for its intended use; a lifetime limited warranty on stainless steel hardware against rust; and a one-year limited warranty on non-stainless steel hardware against rust. The lifetime warranty refers to the life of the product as defined below and covers the product under normal use and proper maintenance. The cost of replacement due to scratching or cutting of certain hardware plating is not included in this warranty.



LIVE

MOVE

Strong.

LIFE.



5726 MARLIN RD. STE 420 CHATTANOOGA, TN 37411
TOLL FREE (855) 728-8700
MOVESTRONGFIT.COM

